

24 IR LEDs Vandal Proof Dome Camera

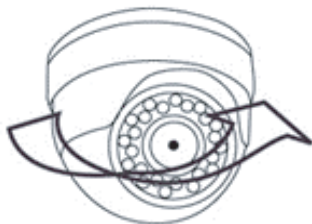

Dimensions (UNIT :mm)

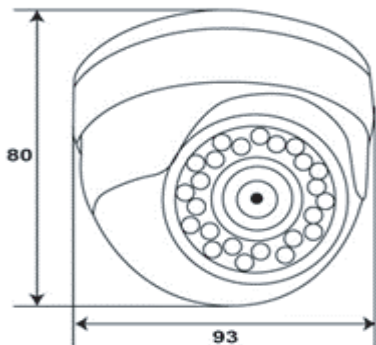

PANNING UPTO 360°

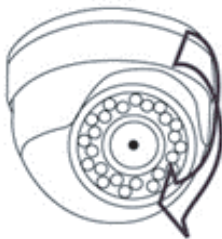

TILTING 10°~90°

Features

- 1/3" SONY Super HAD CCD
- 480 TV Lines
- Fixed Lens
- Built in 24IR LEDs & CDS Sensor
- Surface or Flush Mountable

Specification

ITEM	VD-301
Signal System	NTSC
Image Sensor	1/3" SONY Super HAD CCD Sensor
Effective Pixel	768H x 494V
Resolution	480 TV Lines
Shutter Speed	1/60~1/10,000 sec.
Video Output	VBS 1.0Vp-p(75Ω Load)
Sync. System	Internal
Scanning System	2:1 Interlaced
S/N Ratio	Over 48dB
Min. Illumination	0.5 Lux
Day/Night Function	Built-in Mechanical IR Cut filter
Lens Options	3.6 mm
Gamma	0.45
Power Supply	DC 12V
Operating Temp.	-10℃ ~ +50℃
Dimension	93mm(W) x 80mm(D)

Available Models

NTSC	PAL
VD-100IR: Standard Res.	VD-101IR: Standard Res.
VD-300IR: High Res.	VD-301IR: High Res.

Specification are subject to change without any prior notice.