

Paragon

Large Motor-in-Roller Projection Screen

Ideal for auditoriums and lecture halls

Sizes through 28' wide



Bolsa Comercio Rosario, Argentina

Choose the PARAGON for auditoriums, lecture halls and any setting where a very large screen is required. Sizes up to 21' x 28' for even the largest audiences. Case of aluminum and fire-retardant hardboard can be suspended anywhere, with controls wherever they're needed.

Your choice of a conventional viewing surface: fiberglass matt white or glass beaded.

System Options

- **Extra Drop**—Up to 21' total screen height, either white or black (white standard on AV format screens, black on all others).
- **Black Masking Borders**—Borders are optional for AV format screens and standard for all other format screens.
- **Control Options**—Refer to page 5.

Case Dimensions/Method of Installation

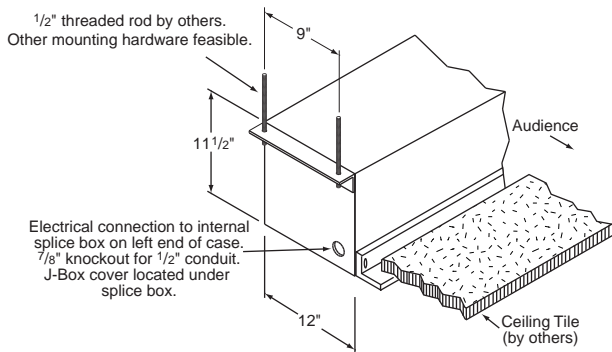

Dimensions & Data—Paragon

Viewing Area HxW	Case Length	Net Wt. (lbs.)	Viewing Area HxW	Case Length	Net Wt. (lbs.)
15' x 20'	20'10"	415	18' x 24'	24'10"	500
20' x 20'	20'10"	430	13' x 26'	26'10"	515
11' x 22'	22'10"	440	19 1/2' x 26'	26'10"	540
16 1/2' x 22'	22'10"	455	14' x 28'	28'10"	555
22' x 22'	22'10"	475	21' x 28'	28'10"	585
12' x 24'	24'10"	475			

NTSC Video Format

Nominal Diagonal	Viewing Area HxW	Case Length	Net Wt. (lbs.)
25'	177" x 236"	20'10"	415
27 1/2'	194" x 260"	22'10"	455
30'	212" x 284"	24'10"	500
32 1/2'	230" x 308"	26'10"	540
35'	248" x 332"	28'10"	585

Case dimensions 11 1/2" high x 12" wide.

Mounting brackets extend 2" beyond each end of case.

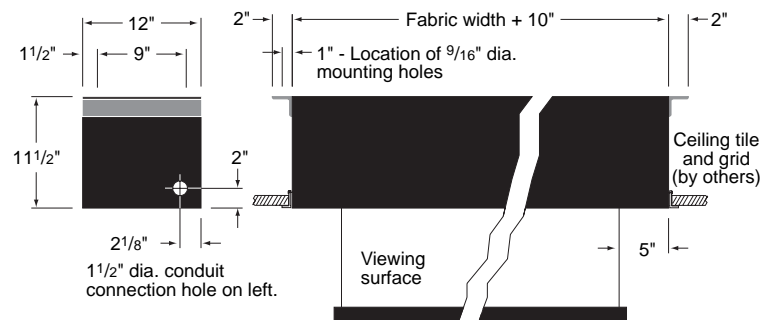

Specifications—Paragon

_____ Projection screens, size _____h. x _____w., electrically operated 110-120 v. AC, 60 Hz. 3-wire motor mounted inside screen roller, instantly reversible, lifetime lubricated, with internal thermal overload protector and mechanical brake. Motor mounted with sound-absorbing fixtures. Preset, accessible limit switches. Entire roller and drive assembly easily removable through bottom of case.

Roller to be heavy gauge 6" OD steel tube. Zinc plated roller brackets to have double row radial ball bearings. Viewing surface to be (fiberglass matt white/glass beaded), flame and mildew resistant. Screens require one or more horizontal seams.

Case constructed of aluminum and fire retardant PVC. Bottom of case fully enclosed except for slot allowing fabric passage. Bottom closure panels may be removed manually for access to roller and drive unit. Steel mounting brackets shall be at least 1/4" thick and attached to each end of case.

Three-position control switch (or switches-specify number) shall stop or reverse screen at any point. Controls to be furnished complete with cover plate.

Entire unit certified by Underwriters' Laboratories, Inc. for the U.S. and Canada.