

7-CHANNEL 2 x 150W MIXING AMPLIFIER



FEATURES

- COMPACT MIXING AMPLIFIER
- 5 LINE INPUTS AND 2 MICROPHONES INPUTS
Especially microphone input #1 has an integrated 'ducking' function which automatically fades the music to background level during announcements.
- MASTER EQUALIZER WITH(6dB bass and treble controls).
- 2 FULL-STEREO MASTER SECTIONS WITH INDIVIDUAL CONTROLS.
- LIMITER FOR INTERNAL POWER AMPLIFIERS TO ELIMINATE OVERLOAD DISTORTION.
- MASTER 1 LINE-LEVEL LOWPASS OUTPUT (100Hz/12dB) WITH BALANCED XLR CONNECTOR FOR CONNECTION OF ACTIVE SUBWOOFERS.

SPECIFICATIONS

- ELECTRICAL * 0dB=1Vrms
 - Output power(1kHz sine, THD < 0.1%)
 - into 4 ohms.....2 x 150 W
 - into 8 ohms.....2 x 100 W
 - bridged into 8 ohms.....1 x 300 W
 - Inputs
 - Line.....5 x RCA phono type (Stereo)
 - Micro.....2 x XLR
(1 = ground, 2 = signal + (hot), 3 = signal - (cold))
 - Outputs
 - SpeakersAmp 1 and Amp 2:binding posts
(red = signal, black = ground)
Bridge Out:binding posts
(red = signal +, black = signal -)
 - Master 2 OutXLR balanced
(1 = ground, 2 = signal + (hot), 3 = signal - (cold))
 - Mono Sub OutFilter:Lowpass 100Hz/12dB
Output connector:XLR balanced
(1 = ground, 2 = signal + (hot), 3 = signal - (cold))
 - Rec Out1 x RCA phono jack (stereo)
 - Distortion (THD)< 0.1%
 - Frequency range18 - 25.000Hz
- GENERAL
 - Power Source.....AC 100V/120V/230V/240V, 50/60Hz
 - Power Consumption261W
 - Weight13kg
 - Dimensions483(W) × 90(H) × 383(D)mm

EMI-300

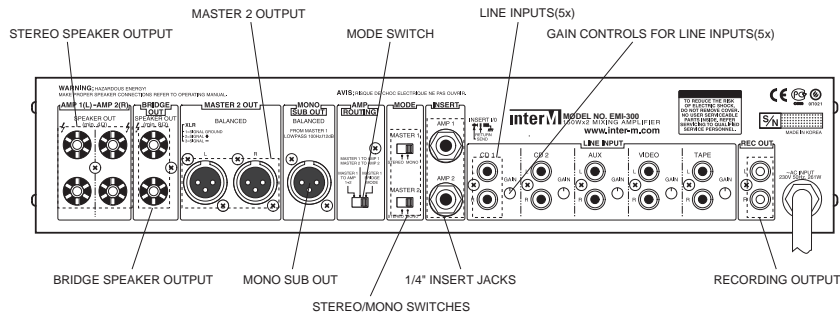
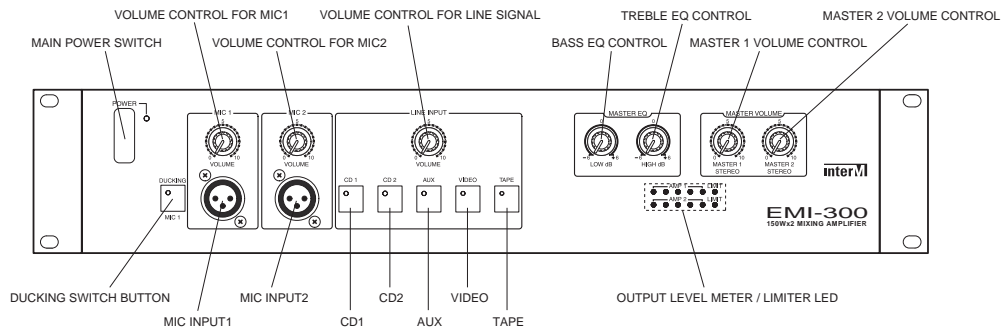

BLOCK DIAGRAM

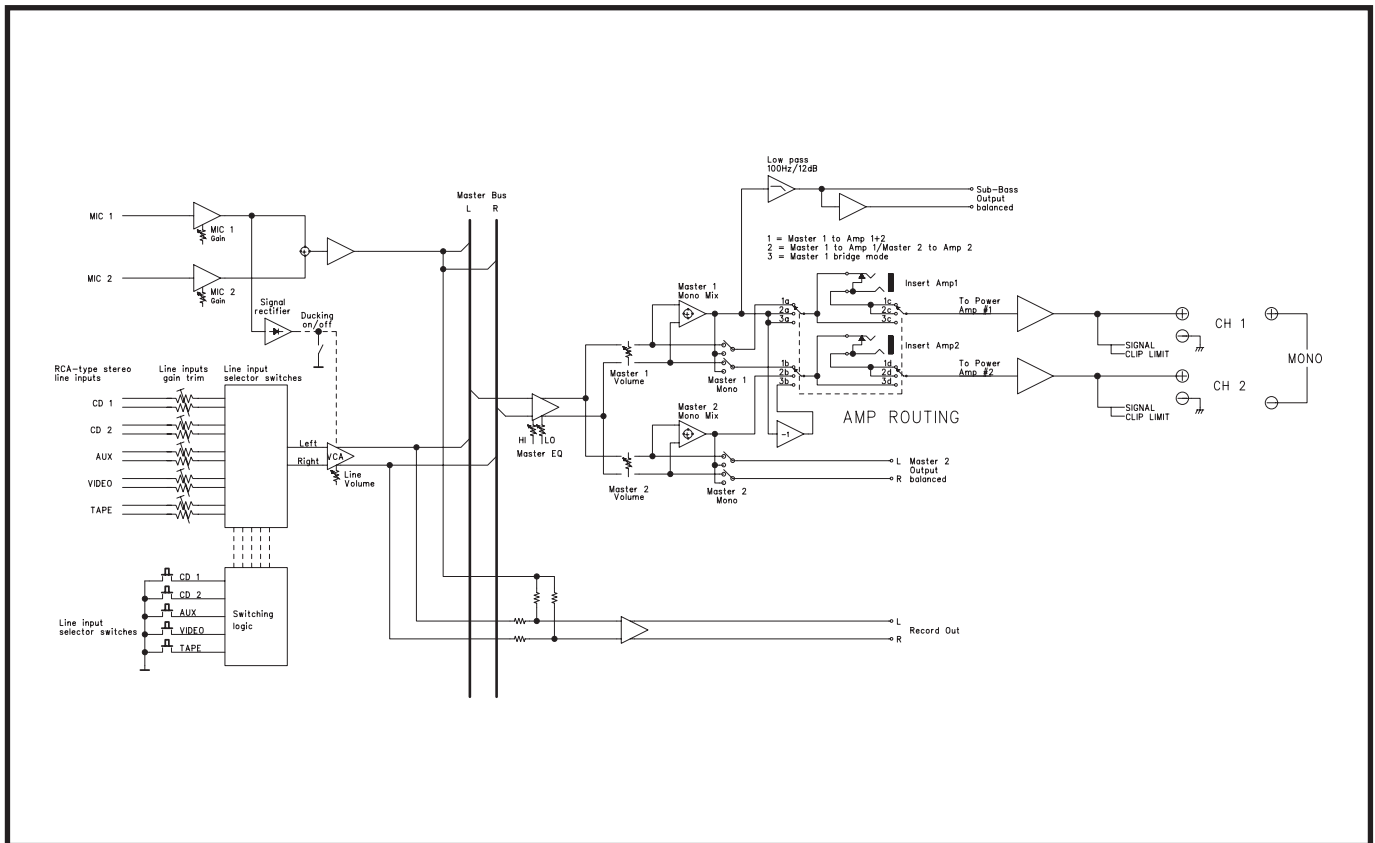

OFFICE : 653-5 BANGHAK-DONG, DOBONG-KU, SEOUL, KOREA TEL : 82-2-2289-8140~8, FAX : 82-2-2289-8149
 Home page : <http://www.inter-m.com> E-mail : export@inter-m.com