

# QD-4240/4480



## QUAD SERIES AMPLIFIER



### FEATURES

- **QUAD AMPLIFIER**  
QD4240/QD4480 series amplifiers combines 4 amp circuit in the one unit.
- **SUBSTANTIAL PROTECTION CIRCUITRY**  
To ensure stability and reliability against over current and overheating, extra protection circuitry is provided. In addition, output muting and DC fault detection circuit is provided to protect the loud speaker.
- **VARIOUS DISPLAY**  
To confirm the operating status, led display are provided for power, protection, clip and signal.
- **MODE SWITCH**  
Operating modes are parallel, stereo and bridged mono.
- **FAN COOLING**  
These amplifiers has 2-step low noise fan.  
Air flow is front to rear.
- **INPUT CONNECTORS**  
Input connections consists of balanced 1/4" phone jack.
- **OUTPUT CONNECTORS**  
Output connectors consist of 5-way binding post.

### SPECIFICATIONS

#### ■ ELECTRICAL

\* 0dB=0.775Vrms

- Rated Output (1kHz, 0.1% THD)

	QD4240	QD4480
at 8Ω 1kHz(Quad CH)	40W x 4	80W x 4
at 4Ω 1kHz(Quad CH)	60W x 4	120W x 4
at 8Ω 1kHz(Bridged Mono)	120W x 2	240W x 2

- Input Sensitivity .....0.775Vrms
- Frequency Response(±0.5dB).....20Hz~50kHz
- T.H.D(20Hz~20kHz) .....Less than 0.03%
- S/N .....105dB
- Channel Separation(8Ω, 1kHz) .....80dB
- Protection.....Turn On Delay, Thermal, DC Fault, PC Limiter

#### ■ GENERAL

- Power Source .....AC 120V/230V/240V, 50/60Hz
- Power Consumption .....QD4240:300W  
QD4480:420W
- Weight .....QD4240:11.5kg  
QD4480:15.5kg
- Dimensions .....482(W) x 88(H) x 369(D)mm

# QD4240/4480

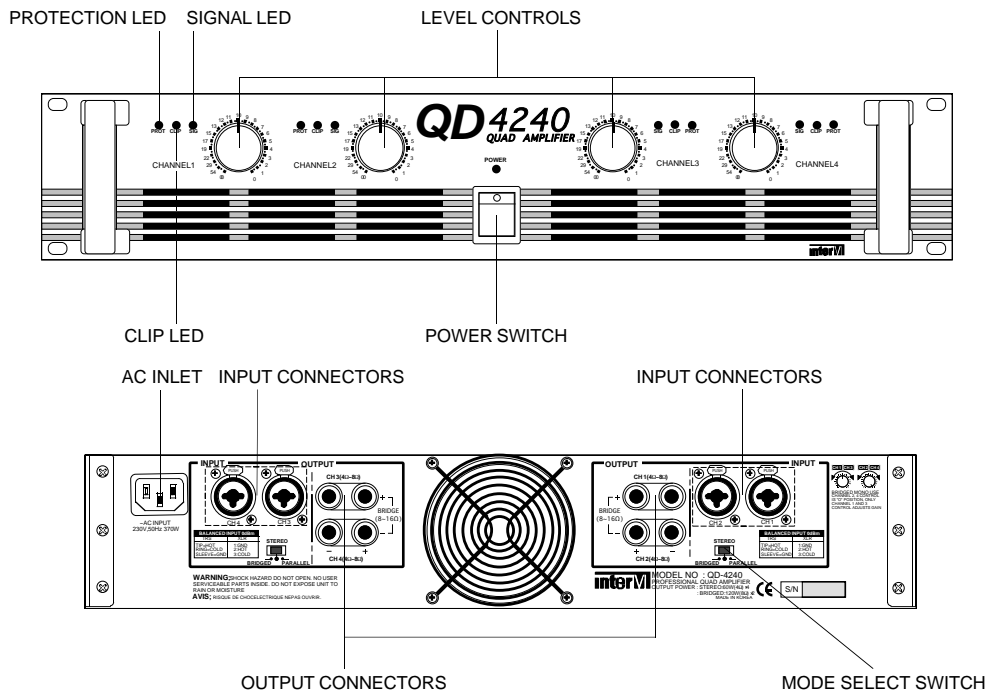

## BLOCK DIAGRAM

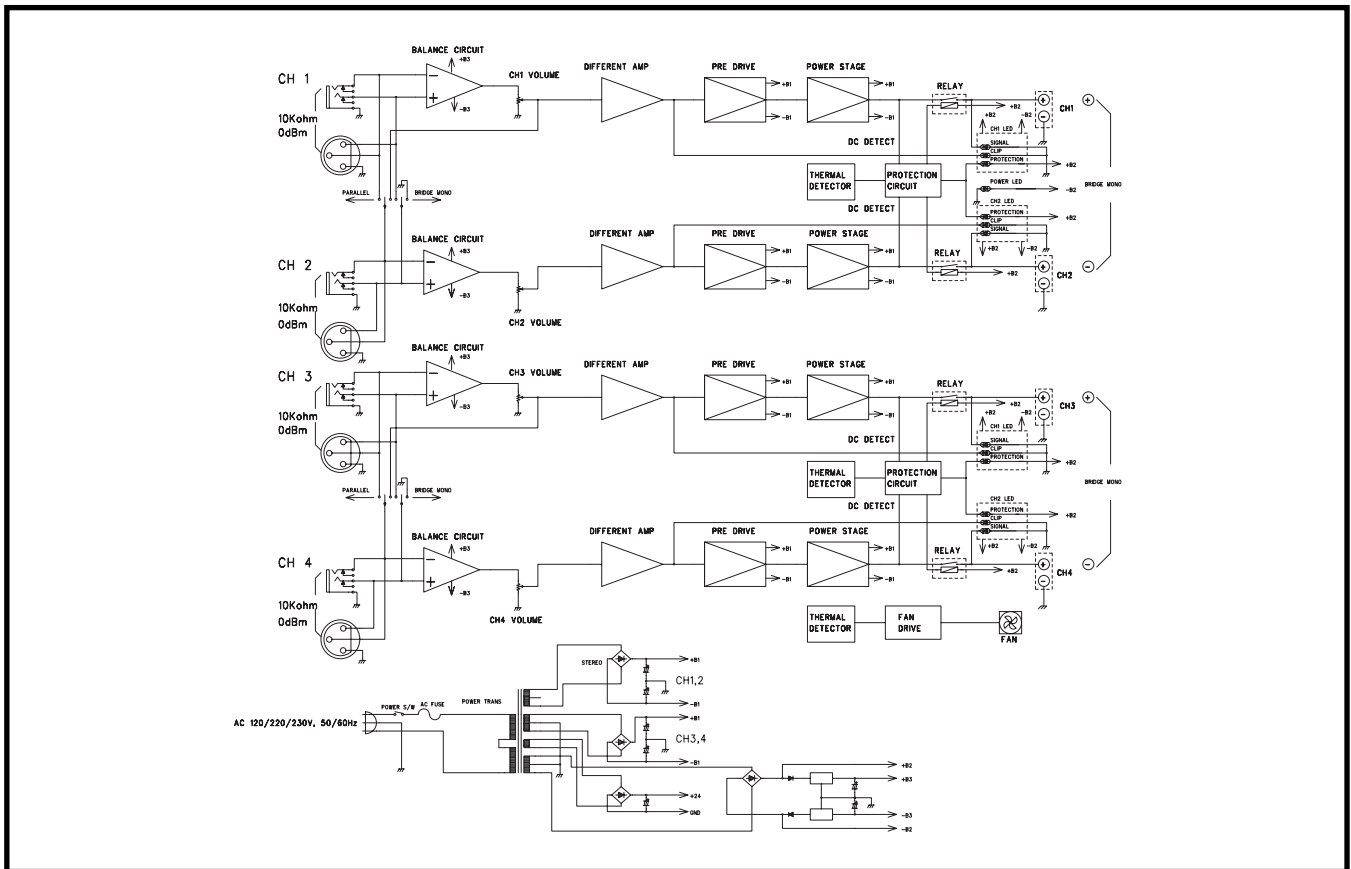

**interM**

OFFICE : 653-5 BANGHAK-DONG, DOBONG-KU, SEOUL, KOREA TEL : 82-2-2289-8140~8, FAX : 82-2-2289-8149

Home page : <http://www.inter-m.com>

E-mail : [export@inter-m.com](mailto:export@inter-m.com)

9047920710 D